

Application:

The Oventrop boiler connection system “Regumat-180” DN 32 - pump length 180 mm - allows for a time-, cost- and space-saving connection of the boiler to the pipework. The “Regumat-180” stations are available with or without high-efficiency pumps.

Advantages:

- pre-assembled connection system for pumps with a length of 180 mm
- high quality materials
- with pump ball valve at the pump inlet
- universal thermal insulation of modular construction supplied with each “Regumat”
- easy installation by use of tailpipe sets
- no hemp sealing
- integrated wall mounting device
- supply and return pipe can be changed on site

Choice of the “Regumat-180” stations:

Product assembly DN 32 for pump length 180 mm

The “Regumat-180” with pump ball valve is available with or without high-efficiency pump

- as basic model (without mixing valve)
- as model with three-way mixing valve and actuator

Dimensions: H = 530 mm, W = 350 mm , D = 221 mm



“Regumat M3-180” DN 32

	Model <u>without</u> mixing valve	Model <u>with</u> mixing valve
	“Regumat S-180”	“Regumat M3-180”
Isolation device with 2 ball valves and 2 thermometers (without pressure relief device)	X	X
Wall mounting device	X	X
Flanged pipe with check valve	X	X
Distance piece	X	
Three-way mixing valve with actuator (suitable for standard boiler regulations)		X
Pump ball valve at the pump inlet	X	X
Thermal insulation	X	X

Tailpipe sets are available as accessories.

Tender specification: "Regumat S-180" DN 32 - constant temperature heating circuit

Product assembly for the connection of the boiler to the pipework.

Consisting of: Isolation device with 2 ball valves for the isolation of the heating circuit, 2 thermometers integrated in the handles of the ball valves for flow and return temperature display, 1 pump ball valve at the pump inlet, flanged pipe with check valve in the return pipe to avoid gravity circulation as well as universal thermal insulation of modular construction.

Materials:

Valves and fittings: Brass
Seals: EPDM

Connections:

To heating circuit: G 2 male thread, flat sealing
To boiler: G 2 male thread, flat sealing
Pump: G 2 male thread, flat sealing

Technical data:

Nominal size: DN 32
Max. operating pressure: 10 bar (PN 10)
Max. operating temperature: 95 °C
Opening pressure check valve: 20 mbar
k_{vs} value: 9.8
Recommended application range: max. 70 kW
(ΔT = 20 K, Δp = 100 mbar)

Models:

without high-efficiency pump	Item no.: 1355075
with high-efficiency pump (EEI ≤ 0.2)	
Grundfos ALPHA 2.1 32-60	1355076
Wilo-Stratos PICO 30/1-6	1355079

Function:

The station "Regumat S-180" for the isolation of the heating circuit consists of an isolation device with thermometers integrated in the handles of the ball valves and a distance piece for length compensation in the supply pipe. The flanged pipe with check valve integrated in the return pipe avoids gravity circulation.

Note:

When the high-efficiency pump is switched off, a low gravity circulation depending on the circulation pressure is still possible within the heating system as the check valve is not tight sealing. On delivery, the supply pipe is on the right hand side. If required, the supply and the return pipe can be changed on site (see installation instructions).

To avoid malfunctions caused by impurities, the installation of an Oventrop strainer is recommended. The installation has to be flushed thoroughly before commissioning.

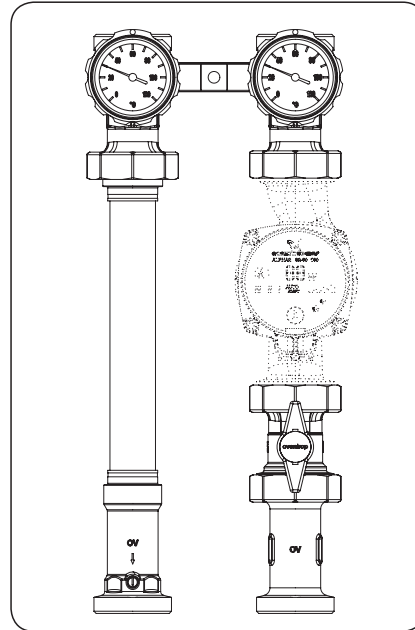

"Regumat S-180"

Tender specification: "Regumat M3-180" DN 32 - variable temperature heating circuit

Product assembly for the connection of the boiler to the pipework.

Consisting of: Isolation device with 2 ball valves for the isolation of the heating circuit, 2 thermometers integrated in the handles of the ball valves for flow and return temperature display, 1 pump ball valve at the pump inlet, flanged pipe with check valve in the return pipe to avoid gravity circulation, three-way mixing valve with mounted actuator as well as universal thermal insulation of modular construction.

Materials:

Valves and fittings: Brass
Seals: EPDM

Connections:

To heating circuit: G 2 male thread, flat sealing
To boiler: G 2 male thread, flat sealing
Pump: G 2 male thread, flat sealing

Technical data:

Nominal size: DN 32
Max. operating pressure: 10 bar (PN 10)
Max. operating temperature: 95 °C
Opening pressure check valve: 20 mbar
Actuator: 230 V, 90°/140 sec., 5 Nm
k_{vs} value: 8.1
Recommended application range: max. 65 kW
(ΔT = 20 K, Δp = 100mbar)

Models:

without high-efficiency pump	Item no.: 1355275
with high-efficiency pump (EEI ≤ 0.2)	
Grundfos ALPHA 2.1 32-60	1355276
Wilo-Stratos PICO 30/1-6	1355279

Function:

The "Regumat M3-180" has the same design and function as the "Regumat S-180". It is additionally equipped with a three-way mixing valve with mounted actuator. The three-way mixing valve serves to control the flow temperature.

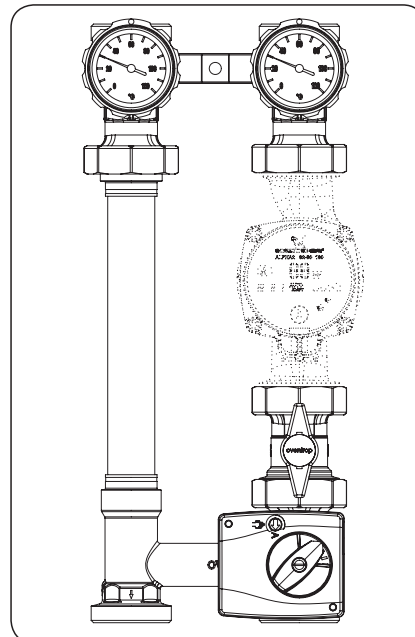

"Regumat M3-180"

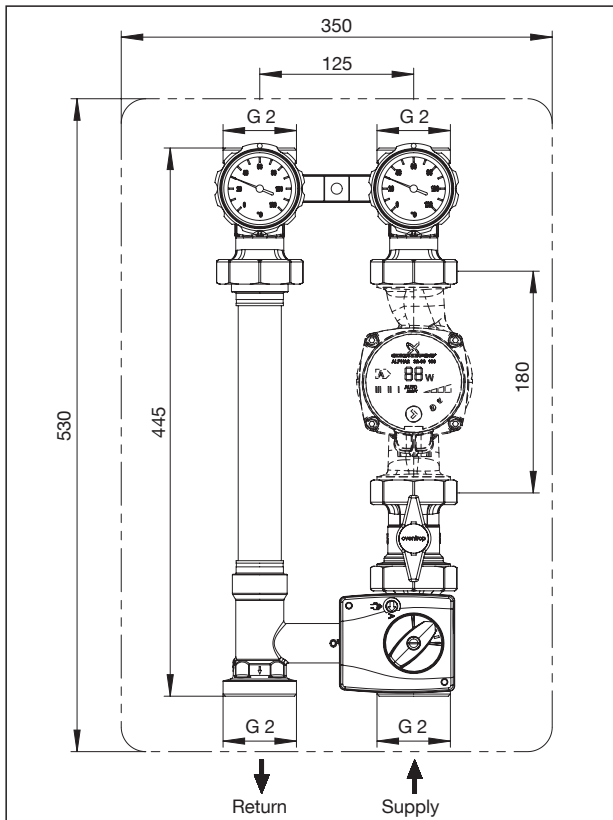

Dimensions "Regumat M3-180" DN 32

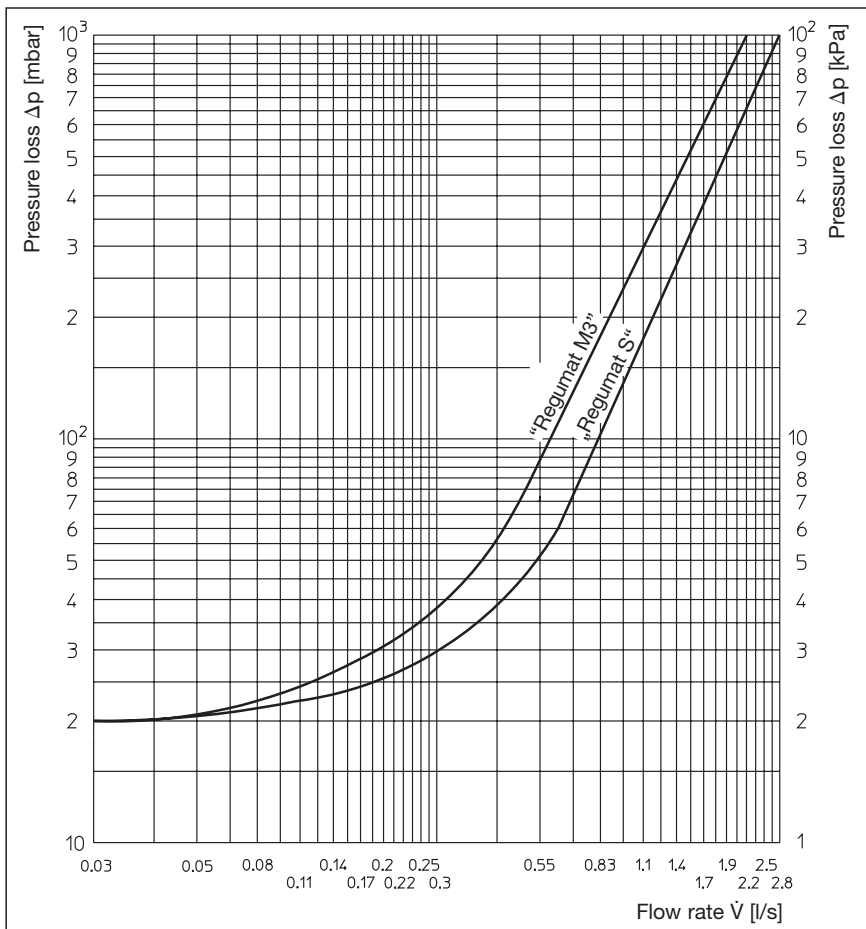

Flow chart

Subject to technical modifications without notice.

Product range 6
ti 290-EN/10/MW
Edition 2017